

# HOBBYNOX™

## FLOW-TF

*Top Feed Airbrush Set with 0.3/0.5/0.8 mm Nozzles*



# MANUAL

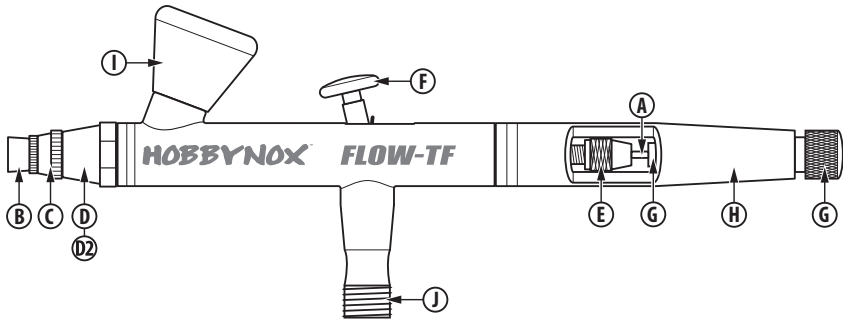

## Hobbynox FLOW-TF Airbrush Set

First we want to thank you for purchasing the Hobbynox FLOW-TF top-feed double-action airbrush set. The FLOW-TF is the perfect first airbrush that is meant to be used with waterbased non-toxic paints such as our Hobbynox Airbrush Colors or similar from Createx or Parma Faskolor etc.

It's suitable for most types of airbrush work but painting Lexan bodysells for RC cars, painting fishing lures & baits and most small to mid-sized items and models is what the TF excels at.

The TF is a complete set that is ready to be used and it connects easily to the Hobbynox Airbrush Compressors or any other airbrush compressor that has an G1/8 male threaded coupler.

### Included Items:

- Hobbynox FLOW-TF - Top Feed Airbrush Set - #HN002-00
- Nozzle/Needle Sets - 0.3 / 0.5 / 0.8 mm
- Paint Cups - 2 / 5 / 13 cc
- Braided Hose - 1.8 m long - G1/8 Female & G1/8 Female
- Compressor Adapter - G1/8 Male to G1/4 Female
- Tool & Printed Manual

## Description

- A. Needle.** Out of the box there is a 0.5 mm needle set installed in your FLOW-TF airbrush. To remove the needle, first unscrew the back handle (H) and then by hand untighten the threaded needle holder clamp nut (E). Then carefully pull back the needle out of the needle holder unit. Be careful to not bend the sharp tip of the needle!
- B. Funnel Cap.** The funnel cap directs the paint that comes out of the nozzle/tip and is threaded in place with hand tight pressure. The FLOW-TF airbrush can be used without the cap if you are painting fine details but be careful not to bend the tip of the needle as it will be exposed!
- C. Nozzle.** The nozzle is matched to the needle and tip size and is hand threaded medium tight.
- D. Air Cap.** The air cap holds and aligns the needle tip and it's hand tightened with the included tool.
- D2. Needle Tip.** The tip is matched to the needle and nozzle and it's a 0.5 mm tip installed from the factory (0.3 & 0.8 mm sets are also included in the box).
- E. Needle Clamp Nut.** It's hand tightend to hold the needle to the needle holder unit. Unscrew it 1/4-turn when removing the needle.
- F. Trigger.** Push down for gradually more air and pull back to gradually increase paint flow.
- G. Back-Stop Adjustment.** The rear nut is threaded to allow adjustments of the back-stop movement of the needle unit. That can be useful if one wants to limit the maximum possible paint flow (when trigger is fully back).
- H. Rear Handle.** Use only light force when tighten it.
- I. Paint Cup.** The included paint cups (2, 7 & 13cc) are changeable and are threaded into the airbrush body with light hand pressure. There is an o-ring inside the airbrush body to seal against the paint cup edge.
- J. G1/8 Male Thread.** Tighten the included hose adapter with medium force.

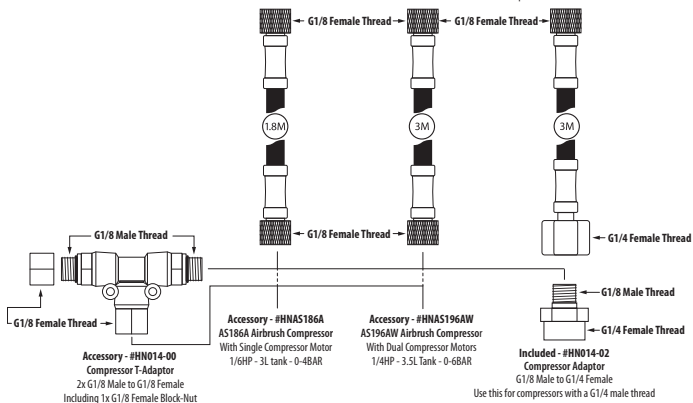
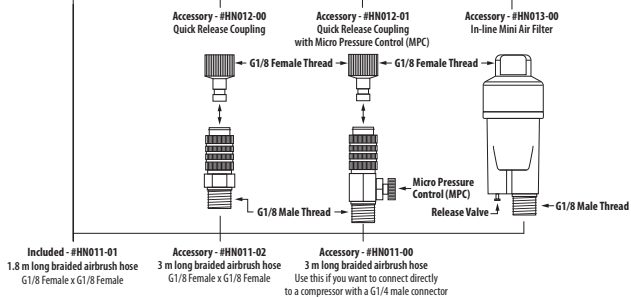
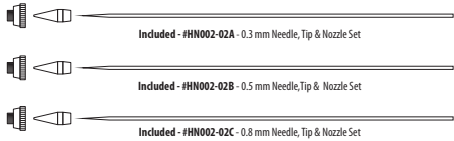
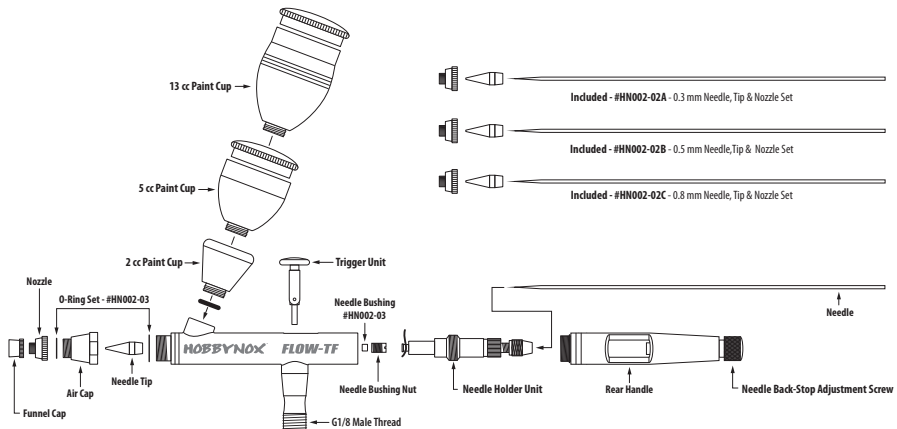

- |   |  |
|---|--|
| HN002-01A ...FLOW-TF/BF - 0.3 mm Needle, Nozzle & Tip Set .....       | HN013-00 ...Mini Air Filter - G1/8 Female & G1/8 Male Threads .....    |
| HN002-01B ...FLOW-TF/BF - 0.5 mm Needle, Nozzle & Tip Set .....       | HN014-00 ...Compressor T-Adapter - 2x G1/8 Male & G1/8 Female ....     |
| HN002-01C ...FLOW-TF/BF - 0.8 mm Needle, Nozzle & Tip Set .....       | HN014-01 ...Compressor Adapter - G1/8 Female & G1/4 Male .....         |
| HN002-02 ...FLOW-TF/BF - O-Ring Set .....                             | HN014-02 ...Compressor Adapter - G1/8 Male & G1/4 Female .....         |
| HN011-00 ...3.0 m Braided Hose - G1/8 Female x G1/4 Female .....      | HN018-00 ...Airbrush Cleaning Station (incl. 3 filters) .....          |
| HN011-01 ...1.8 m Braided Hose - G1/8 Female x G1/8 Female .....      | HN018-01 ...Spare Filters to the Airbrush Cleaning Station (10pcs) ... |
| HN011-02 ...3.0 m Braided Hose - G1/8 Female x G1/8 Female .....      | HN017-00 ...Airbrush Holder 2+2 (with Air Regulator Holder) .....      |
| HN012-00 ...Quick Release Coupling - G1/8 Female & G1/8 Male .....    | HN013-01 ...Air Regulator & Manometer Unit .....                       |
| HN012-01 ...Quick Release MPC Coupling - G1/8 Female & G1/8Male ..... |  |

## Learning to Airbrush

If you are starting your new airbrushing hobby you will quickly notice that it's very fun and creative - the sky is the limit on what you can do with it!

When you are new to airbrushing it's a lot to learn and we recommended that you test different techniques to learn what works best for you.

For more info search for example youtube and you will get plenty of videos that show different airbrushing techniques etc.

*Note, there is not two individuals that airbrush the same!*

## Thinning the Paint

Use the manufacturer recommended paint reducer. With modern waterbased paints though you may get away with using just water as a reducer. But with water as a reducer you can get yourself into issues though as eventually the water content in the mixed paint gets too high and that can create not preferred end results including excessive tip/nozzle paint clogging.

At least do yourself a favor and buy a bottle of the manufacturer recommended reducer and test it to see the difference.

### Not Enough Reducer:

- Excessive clogging of the airbrush tip/nozzle.
- Cobwebbing of the paint - as in the paint dries before it even hits the surface to be painted.
- You can hear a "dry noise" from the airbrush nozzle while painting.
- Solution: Add more reducer and/or increase air pressure.

### Too Much Reducer:

- Paint runs (that can also happen if you are airbrushing too close to the painted surface or too high air pressure).
- Paint coverage is weak.
- Solution: Increase the distance from the airbrush nozzle vs the surface to be painted, add more paint to the mix (making the paint mix thicker) and/or lower the air pressure.

## Air Pressure

Normally the air pressure needs to be stable and constant. For that reason we recommend an airbrush compressor with a 3L air tank and that it can produce around 20 liters of airflow per minute to be on the safe side with the FLOW-TF. The air pressure range that is normally used is around 2-3.5 BAR depending on the needle/tip size and how small/big details you will paint.

## Recommendations

### Small Details & Thinner Paint = Lower Air Pressure

**& Smaller Tip Size:** With the FLOW-TF airbrush that means you will use the the 2 or 5cc paint cup and normally the 0.5 mm needle/tip set. With this set-up you can paint most smaller items such as fishing lures and medium sized custom details.

### More Covering & Less Thin Paint = Higher Air Pressure

**& Bigger Tip Size:** With the FLOW-TF that means using the 0.5 or 0.8 mm needle/tip set together with the largest 17 cc paint cup and you can get pretty good covering for painting "bigger" models such as a normal sized Lexan RC car body or a helmet etc. The happy medium is to use the 0.5 mm needle/tip that is standard installed in the airbrush until you are familiar with it and has built up your airbrushing experience.

## Airbrush Issues

Normally any issues you will have regarding the function of your airbrush is due to not enough maintenance or that you have an air leak somewhere.

So of that reason the cleaning, disassembly and reassembly of your airbrush is the most important things to do correctly and frequently to get a good constant function.

If there is no paint coming through the tip/nozzle it's most likely clogged with paint build up. Clean it again and maybe increase the amount of reducer in the paint mix to reduce the clogging and increase the air pressure. Try also to go one step up on the needle/tip size of just adjust the needle backwards to allow more paint to flow through.

If it's air bubbles in the paint cup there is most likely an air leak. Re-tighten the funnel cap, nozzle and/or air cap.

## Cleaning Your Airbrush

If you use our Hobbynox Airbrush Colors then you can use normal tap-water to clean most parts of your Hobbynox FLOW-TF airbrush. Don't let the paint sit in the airbrush for too long though or it can get difficult to flush out - it's best to clean the airbrush directly after you are done painting.

If water is not enough to remove the paint residue - Use our Hobbynox SP Reducer/Cleaner!

If possible don't use any other type of paint thinner to clean the airbrush with as the o-rings can get damaged.

### Cleaning Procedure:

1. Empty the paint cup from any remaining paint into the waste bin. Remove excessive paint inside the cup with a paper towel.
2. Fill the paint cup with water and pull back/push down the trigger and put the airbrush into a cleaning station or aim it down into a waste bin. Flush the airbrush until there is no visible paint left and the water that is sprayed out is clean.
3. Fill the paint cup with our Hobbynox SP Reducer/Cleaner and flush the airbrush with it. Use a small nylon paint brush to help remove any paint that is still left.
4. Use a paper towel and hold it in front of the nose of the airbrush and pull the trigger all the way back and push the trigger down. You will create a back-pressure and paint that is still inside the airbrush will come out inside the cup. Clean the cup with a paper towel. Repeat if necessary.
5. Use a paper towel and SP Reducer/Cleaner to clean the outside of the airbrush. Done.
6. Every once in a while take the airbrush apart to clean it.

## Compressor After Use

When you are done painting and you have cleaned your airbrush thoroughly - empty the air tank of your compressor either by pressing the release valve under the airfilter/regulator or by unscrewing the tank draining plug. It's also good advice to use the drain valve every once in a while to remove any moisture that trapped in the tank due to humidity & moisture in the air.



## Brushes with Synthetic Bristles

We recommend that you get a couple of small paint brushes with synthetic bristles.

A synthetic brush will help you considerably when cleaning the airbrush of paint that is not removed when you just flush it with water or our Hobbynox SP Reducer/Cleaner.



## Dental Mini/Micro Brushes

If you really want to clean the hard to reach areas of your airbrush there are mini- and micro-sized brushes available from your local pharmacy. Their main intended use is to brush between your teeth but they're also excellent for cleaning your airbrush hard to reach spots!

There are several sizes available and you need to test which ones works the best for you - the ones we have tested is in the 0.5 to 0.7 mm range and they work very good.

# HOBBYNOX™

## AIRBRUSH COLORS



### Wide Color Range

Hobbynox Airbrush Colors include a wide assortment of Solids (Opaque), Transparents, Neons, Pearls, Iridescent, Change and Glow colors.

For more Hobbynox Airbrush Color info visit us at:

[www.minicars.se](http://www.minicars.se)

### Your Airbrush

Hobbynox Airbrush Colors work best out of the bottle with a 0.5 mm tip-sized airbrush operated @ 2.8-3.5 BAR.

For smaller tip-sizes, lower the BAR settings and fine-line detailed artwork - reduce the paint with Hobbynox SP Reducer/Cleaner until the desired viscosity and atomization is reached (normally 5-10% by volume and max up to 25%).

**After use:** use normal water to flush out the remaining paint directly after use and finish off the cleaning process with our SP Reducer/Cleaner to flush through the airbrush until it's totally clean.

### Water-Based & Non-Toxic

Our water-based, non-toxic airbrush paints are made with light-fast pigments, durable resins and quality ingredients. Hobbynox Airbrush Colors works on polycarbonate (Lexan®) and most other plastics, wood, metals and more.

Hobbynox Airbrush Colors remains flexible and resists cracking, chipping and most impact damage.

If needed Hobbynox Airbrush Colors can be cleared with most 1K and 2K clear coats (including automotive top-coat clears).

### Use Hobbynox Airbrush Colors to paint:

- RC Polycarbonate BodysHELLS
- Custom Paint Jobs
- Fishing Lures & Crankbaits
- Model Kits
- RC Boats
- Helmets
- And More!

### Temperature & Humidity

The optimum temperature range for using Hobbynox Airbrush Colors are 21-26°C and with less than 50% humidity.

Hobbynox Airbrush Colors cure with the assistance of mild-heat and airflow (use an hairdryer set on low to assist drying).



## **Hobbynox Solid Colors**

Opaque/Solid paints are the base of the Hobbynox Airbrush Colors. They are suitable for any airbrush work and can be mixed with any other Hobbynox Airbrush Color. Note that solid white is the color that needs most SP Reducer/Cleaner as it has the most dense pigment content of all our paints.

## **Hobbynox Transparent Colors**

Perfect to use when fading/mixing with other transparent colors or back them with solid white for a lighter appearance, or any other Hobbynox Airbrush Color for a custom effect. Use either Pearl Silver or Pearl Gold backing for a pearl type look or Chrome for a deeper metallic look. They can be backed or mixed with any Hobbynox Airbrush Color.

## **Hobbynox Chrome Color**

Chrome can be used as "silver" (faster drying and thinner, more transparent, than pearl silver) or backed with Solid Black for a brilliant satin chrome finish. Chrome can also be used to cover transparent colors for a deep metallic look.

## **Hobbynox Pearl Colors**

Pearl colors are vibrant paints made by combining pearlescent pigments of various type. A difference when compared to a metallic paint is that pearl colors are not limited to sparkle with silver alone and the color-effect looks a little deeper.

They are slightly transparent and can be backed or mixed with any Hobbynox Airbrush Color.

## **Hobbynox Iridescent Colors**

The Iridescent Colors are Pearl paints with an added hue shift that changes its appearance mostly on contours and edges of the painted item. They are slightly transparent and can be backed or mixed with any Hobbynox Airbrush Color.

## **Hobbynox Neon Colors**

Neon Colors are very vivid colors and are transparent so they need to be backed with solid white for optimum neon effect. Note that Neon Colors are not UV stable - they will eventually fade due to exposure of direct sunlight.

## **Hobbynox SP Reducer/Cleaner**

Use SP Reducer/Cleaner with Hobbynox Airbrush Colors when a thinner paint viscosity is wanted/needed. Generally add 5-10% per volume to paint (especially the solid colors). It may be added in greater volumes to achieve best viscosity for optimum atomization of the paint (normally max up to 25%).

After mixing with SP Reducer/Cleaner the mixed paint has a 72 hour pot-life.

## **Hobbynox Intercoat-Clear 2-in-1**

The Intercoat-Clear 2-in-1 is a water-based polyurethane clear cover that can be used as a protective coat over Hobbynox Airbrush Colors or preferably directly mixed with the paint (5-10%) for improved spray performance, improved coating durability and urethane-like performance with automotive airbrushing on hard surfaces.

Leveling/smoothness and airbrush flow on non-porous surfaces is greatly improved and our Airbrush Colors dry hard and durable when mixed with Intercoat-Clear 2-in-1 (the dried paint can also be taped/masked on also which is a nice feature).

If you are adding just a small amount of Intercoat-Clear 2-in-1 into the paint it improves the appearance and performance greatly for a smoother better looking finish!

Intercoat-Clear 2-in-1 also serves as an adhesion promoter (for painting hard surfaces) when mixed with Hobbynox Airbrush Colors. Use the Intercoat-Clear 2-in-1 mixed Airbrush Colors within 6 hours and keep mixed colors capped airtight after use.

## **Painting on the in- or outside**

*Note, the mentioned recommendations of "backing" colors is aimed at for when one is painting in "reverse" like painting on the inside of a transparent Lexan® R/C car bodyshell. When painting on the outside of the object you need to apply the base/covering color first and apply the top-color afterwards...*

## **Not all colors are the same**

*Note, that there are differences even within a color group regarding how much they need to be reduced. In general the solid colors need more reducer than any other colors (especially solid white).*



## Hobbynox AS186A Compressor

- Single cylinder piston compressor with air tank and auto-stop / auto-stop function suitable for a single airbrush
- Power: 1/6 HP
- Noise Level: 47dB
- Max Air Flow: 20-23 litre/minute
- Auto Start at: 3 BAR (43PSI)
- Auto Stop at: 4 BAR (57PSI)
- Air Pressure Adjustable Range: 0-4 BAR
- Air Tank: 3 litre
- Suitable airbrush nozzles: 0.2-0.8 mm
- Air Outlet Thread: G1/8 (BSP) male
- Size: L317 x W140 x H360 mm
- Weight: 8.2 kg



## Hobbynox AS196AW Compressor

- High capacity dual cylinder piston type compressor with air tank suitable for multiple airbrushes & mini spray gun
- Power: 1/4 HP
- Noise level: 47dB
- Max Air Flow: 35-40 litre/minute
- Air Pressure Adjustable Range: 0-6 BAR
- Air Tank: 3.5 litre
- Dual Air Pressure Modes: One for airbrushing (4 BAR) and one for airtools (6 BAR)
- Suitable airbrush nozzles: all sizes
- Air Outlet Thread: G1/8 (BSP) male
- Size: L350 x W140 x H360 mm
- Weight: 10.7 kg

# minicars

[www.minicars.se](http://www.minicars.se)

### Distributed in Europe by:

Minicars Hobby Distribution AB

Annelundsgatan 17C

749 40 Enköping, Sweden

Phone: +46-171-14 30 00

E-mail: [service@minicars.se](mailto:service@minicars.se)

Web: [www.minicars.se](http://www.minicars.se)

FB: [www.facebook.com/MinicarsHobbyDistributionAB/](https://www.facebook.com/MinicarsHobbyDistributionAB/)